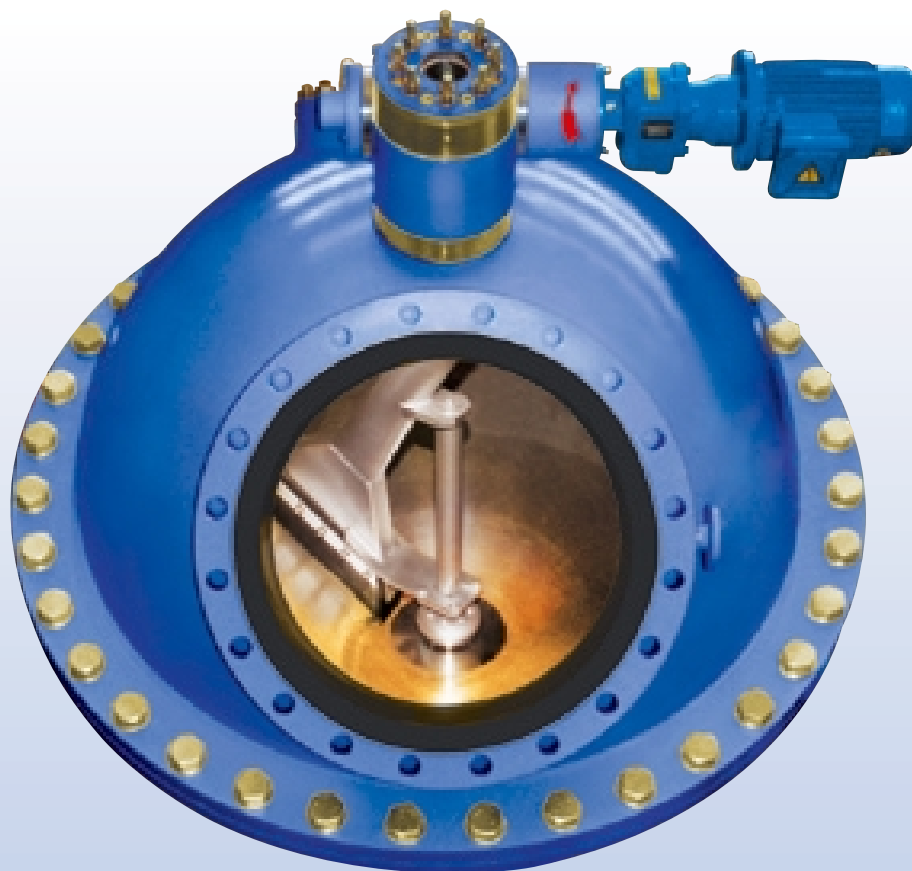

IN-TA-CT[®]

Filter Type PR-BW 100

The Taprogge logo consists of a red circular icon with a white stylized arrow pointing to the right, followed by the word "Taprogge" in a bold, blue, sans-serif font.

Filtration

3

Debris Filter for Cooling Water and other Liquids

The PR-BW 100 is an automatic Backwash Filter for the separation of macro fouling and other particles from liquids - without interruption of flow. This series masters volume flows of 64 to 5,000 m³/h, covering the filtration needs for filter fineness degrees in the range of 1 to 9 mm.

The compact, spherical filter design enables maximum installation flexibility and minimizes operational costs. The high efficiency of the "Pressure-Relieved Backwash" as basic flushing technology has made the filter a reliable tool in cooling water systems of small and medium sizes, especially for retrofit under limited space conditions. For special executions of this filter series TAPROGGE has successfully furnished proof of mastering even most difficult types of debris, even in cases where traditional filtering technology had failed.

Field of Application:

- Operation in seawater, brackish water, river water, for the protection from macro fouling of objects installed downstream, such as heat exchangers and condensers
- filtration of cooling water in auxiliary cooling circuits of conventional and nuclear power stations
- filtration of main and auxiliary cooling circuits of chemical and petrochemical plants, steel works, and other industrial applications
- preliminary and final filtration stages in the particle filtration of industrial water circuits
- preliminary filtration stage in the production of drinking water from surface water

Filter type PR-BW 100 in a power plant



Filter Design

The filter consists of a spherical housing (1+2) that is parted in the middle and connected by mating flanges. Between the pair of flanges the filter section (4) is fitted. In this way gaps are avoided between the particle-loaded influx side and the clean downstream side of the filter. The filter section is normally made of perforated steel sheet.

The inlet side of the filter section is equipped with a backwash rotor (3). The rotor is guided by two strong bearings and driven by a gear motor (6). The connecting diameter of the rotor is DN 80. In the inlet area the backwash rotor is shaped as a canal that partially covers the filter section. The inlet of the canal consists of an elastic packing. The special design of both canal inlet and packing safeguard the pressure-relief (PR) during filter backwash (BW).

The differential pressure measuring system (7) monitors the adjustable backwash point and initiates the backwash procedure which can additionally be started by a timer.

At the outlet opening (8) connected with the backwash rotor a debris discharge valve is fitted that is opened only for backwash purposes. As a standard it is rated for DN 80, has no contraction, and, with automatic operation, is provided with an actuator.

All functions necessary for automatic filter operation, such as, for control, protection, and signalling, are contained in the control panel.

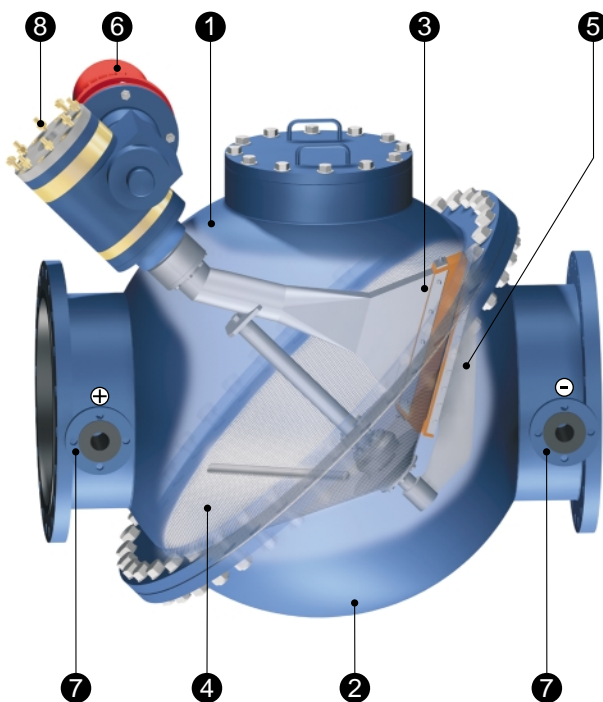

- ① inlet housing
- ② outlet housing
- ③ backwash rotor
- ④ filter section
- ⑤ backwash booster
- ⑥ gear motor
- ⑦ differential pressure measuring system
- ⑧ outlet opening



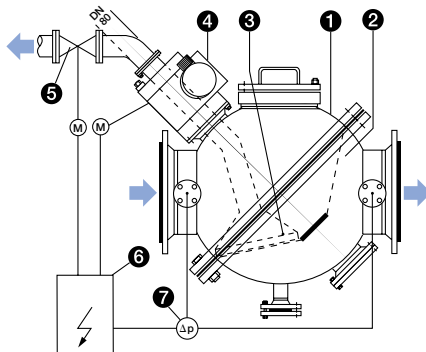

- ① housing
- ② filter section
- ③ backwash rotor
- ④ gear motor
- ⑤ debris discharge valve
- ⑥ control panel
- ⑦ differential pressure measuring system

Filter Function

The medium to be filtered enters into the filter housing (1) via the inlet stud, passes through the filter section (2), and leaves the filter through the outlet stud. Particles that are bigger than the selected filter fineness degree are retained on the filter section.

Via the differential pressure measuring system (7), a timer, or manually by push button, the gear motor (4) is switched on and the debris discharge valve (5) opened. The pressure differential now prevailing between the filter location and the end of the discharge pipe generates a backwash flow (BW = backwash). At the same time the specially shaped inlet canal of the backwash rotor covers the filter section in such a way that the particles to be filtered are relieved from the influx of the medium in this area of the filter section (PR = pressure relieved). The debris particles - thus pressure-relieved - can lift themselves off from the filter section whereupon they are discharged by the backwash flow through the debris discharge pipe. By turning the rotor by 360° the entire filter section is automatically backwashed by its own medium. Upon switching off of the rotor drive (4) the debris discharge valve (5) closes. Filter backwash is thus concluded.

Technical Data

series:	PR-BW 100
volume flow:	64 – 5,000 m ³ /h
connecting diameters:	DN 150 - DN 750
filter fineness degrees:	1.0 - 9.0 mm
filter element:	perforated stainless steel sheet
material of housing:	steel, rubberlined; stainless steel
temperature:	max. 80 °C
control:	programmable controller
debris discharge capacity:	up to 1.4 ltr/m ³ (depending on type of debris)
options:	FilterOptimizer; Remote Monitoring Service
special executions:	for extremely difficult types of macro fouling; for meeting nuclear requirements; explosion proof; special materials

Installation

Sufficient space for installation is scarce at many places, especially with retrofits. This aspect was thus given special attention in filter design. The PR-BW 100 can be installed in any position, that means horizontally, vertically, and under any angle, adapted to the relevant piping. This is reached by twisting the two semi-spherical housing halves on the level of the housing parting against each other, so that the nozzle positions can be adapted to the desired pipe routing - be it as in-line version, or as elbow type instead of a pipe bend, or in any other position.

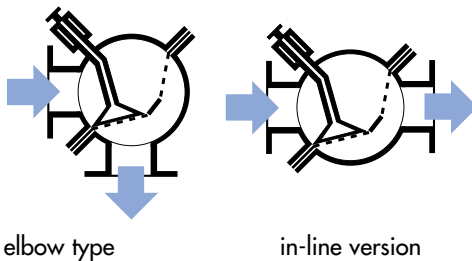

The PR-BW 100 Debris Filter is normally installed directly upstream of an object to be protected, for example a heat exchanger or an additional stage of filtration. The backwash process necessitates a pressure drop in the discharge pipe. If the pressure drop is generated by the object to be protected itself, the flow can be re-injected downstream of the object.

The backwash water can also be discharged atmospherically by making use of the static overpressure downstream of the filter, or also in a pipe via a booster pump.

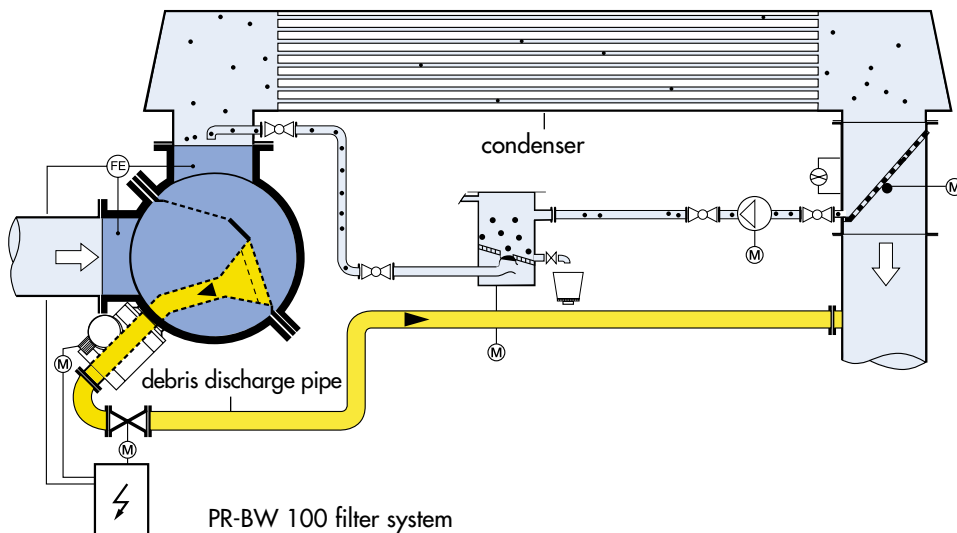

Technical Features and Benefits

Operational Safety

- Well-proven filter with excellent operational experience in industrial applications and power stations
- Safe filtration result by fixed filter section, without gaps between influx and downstream sides of the filter section
- Extremely reliable filter flushing by “pressure-relieved backwash” (PR-BW)
- Special executions for extremely difficult types of debris
- Experience with executions for ex-proof and nuclear systems
- Option: Monitoring of filter operation by Remote Monitoring Service

Economy

- Long-term availability of the operator’s plant through uninterrupted filter operation without manual interference
- Low-cost installation of the filter through 100% installation flexibility: as in-line version, in 90° elbow version instead of pipe bend, or at any other angle directly in the existing pipe.
- Low space requirement through spherical design
- Optimization of operational cost by favourable design:
 - Short backwash times, thus minimized flushing losses
 - Low pressure loss by deflection-free flux towards the filter section, and excellent ratio filter surface/inlet diameter due to spherical shape
 - Low electrical power consumption
 - Low maintenance costs due to filter design incorporating minimum wear and tear
 - In the case of inspection, access to all internal parts without dismantling of filter
- Optional: optimization of operational cost by the TAPROGGE FilterOptimizer

TAPROGGE Care & Comfort Package

Quality right from the Start

- Performance by TAPROGGE as per DIN EN ISO 9001
- Safety of design by fulfilling the requirements of the European Pressure Equipment Directive 97/23/EC
- Application of a management system for safety, health and environmental protection (SCC)
- Standard documentation; documentation upon customer's request, respectively
- The use of extremely corrosion-resistant materials with long lifetimes safeguards the preservation of the value of investment

Compatibility by IN-TA-CT® Modules

- The PR-BW 100 filter is a modular element of IN-TA-CT®, our integral principle for the optimization of cooling water circuits.
- By combination with our TAPIS® prescreening system upstream and a TAPROGGE tube cleaning system type CCS or E1 downstream, an effective overall solution presents itself for the protection of pumps and heat exchangers or condensers installed downstream from problems of coarse debris, micro and macro fouling. Without interfaces - and inclusive of the TAPROGGE System Guarantee.

Competence and Experience out of one Hand

- Application consultancy, project management, fabrication, installation and commissioning of the PR-BW 100 are available from TAPROGGE out of one hand.
- With more than 12,000 successful applications, TAPROGGE can make use of its application-technological experience in its special field that stands unparalleled the world over. This plus of competence is indispensable for difficult media and unknown cleaning behaviour.
- In addition to that, the cooling water test circuits of TAPROGGE's Technological Centre allow a particularly reliable and cost-efficient simulation of site conditions.

Comprehensive Operator Support by IN-TA-S®

- By the installation and commissioning of the PR-BW 100, operators have immediate access to IN-TA-S®.
- By IN-TA-S®, TAPROGGE takes care of the operator in all questions of operation and maintenance. Scope, duration and frequency of the care can be determined by the operator.
- Particularly quick support is available to the users of our Remote Monitoring Service.



© TAPROGGE Gesellschaft mbH. All rights reserved.
TAPROGGE®, IN-TA-CT®, IN-TA-S® and TAPIS® are
registered trademarks of TAPROGGE Gesellschaft mbH.

Postal address:

TAPROGGE Gesellschaft mbH
58292 Wetter
Germany

Company address:

TAPROGGE Gesellschaft mbH
Schliemannstraße 2-14
58300 Wetter
Germany

Tel.: +49 (0)2335 / 762-0

Fax: +49 (0)2335 / 762-245

E-Mail: info@taprogge.de

Homepage: <http://www.taprogge.de>